

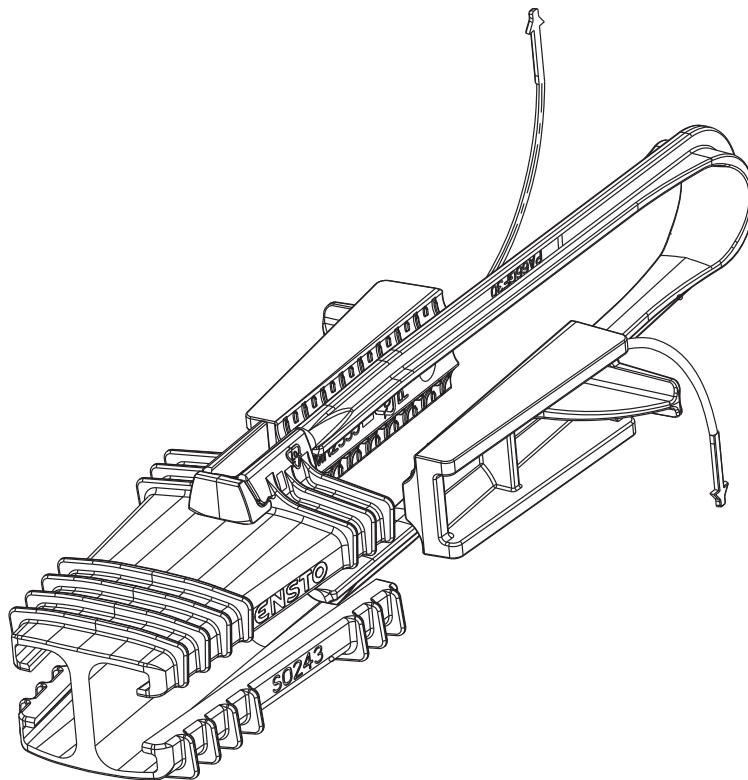

Saves Your Energy

**INSTALLATION INSTRUCTION PEM1040ENG
2011-10**

ENGLISH



TENSION CLAMP S0243

GENERAL INFORMATION

- Check that the product is suitable for the intended installation.
- Check the materials listed in the bill of materials for completeness.
- Read the installation instructions carefully before starting the installation.
- Install carefully and make sure the materials are clean during the installation.
- Clean the working place after the installation.

LEGAL NOTICE

- The product must be installed only by a competent person with sufficient training in installation practices and with sufficient knowledge of good safety and installation practices in respect of electrical equipment. If local legislation contains provisions in respect of such training or sufficient knowledge in respect of installation of electrical equipment such provisions shall be fulfilled by the said person.
- Ensto accepts no liability concerning claims resulting from misuse, incorrect installation or ignored national safety regulations or other national provisions.
- WARNING: Failure to follow the installation instructions may result in damage to the product and serious or fatal injury.

Product	EAN	Conductor size mm ²	Cable diameter mm	SMFL kN
S0243	6418677437977	2-4 x (6-25)	5.3-9.1	2.0

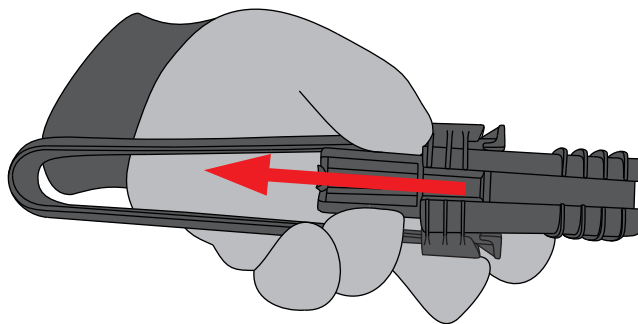

1. Take the wedges out from the body.

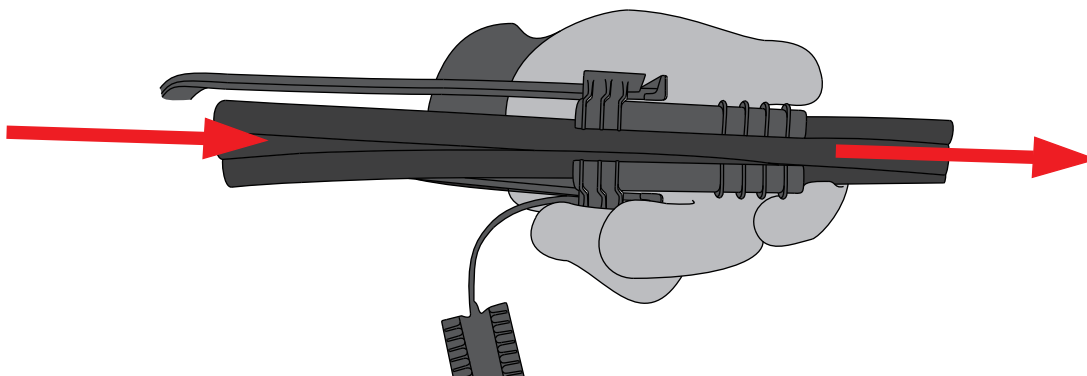

2. Place the conductors inside.

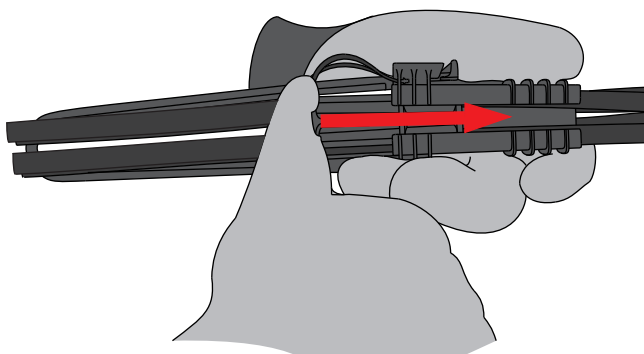

3. Clamp the conductors with the edge.

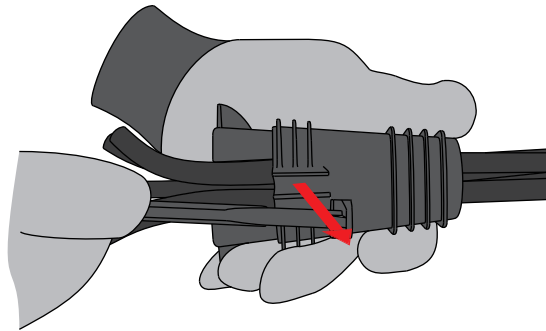

4. (Optional) In case of a closed hook, open the bail.

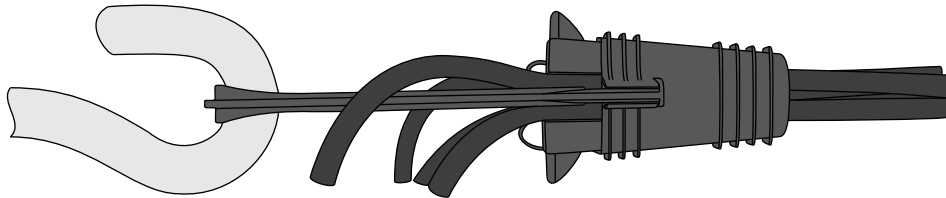

5. Place the clamp to the hook.

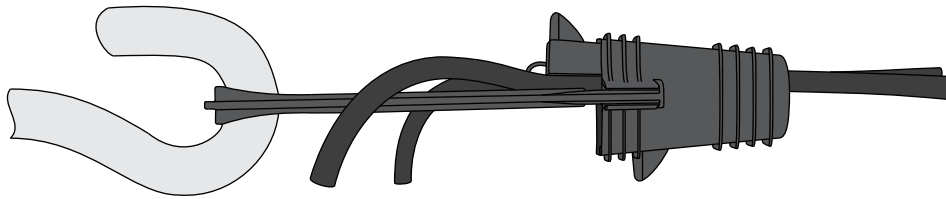

6. (Optional) In case of 2-core bundle cable - use only one wedge.





Saves Your Energy

ENSTO FINLAND OY
ENSIO MIETTISEN KATU 2, P.O.BOX 77
06101 PORVOO, FINLAND
TEL. +358 204 76 21
FAX +358 204 762 770
UTILITY.NETWORKS@ENSTO.COM

WWW.ENSTO.COM