

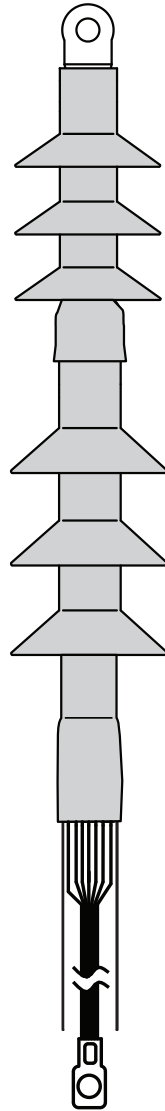

*Saves Your Energy*

**INSTALLATION INSTRUCTION PEM1178ENG  
2015-04**

**ENGLISH**



**COLD SHRINK TERMINATION FOR SINGLE CORE CABLES WITH Cu WIRESHIELD  
 $U_0/U = 20.8/36$  kV,  $U_m = 42$  kV  
OUTDOOR TERMINATIONS COT1.42**

## GENERAL INFORMATION

- Check that the kit is suitable for the cable type.
- Check the materials listed in the bill of materials for completeness.
- Read the installation instructions carefully before starting the installation.
- Install carefully and make sure the materials are clean during the installation.
- Clean the working place after the installation.

## LEGAL NOTICE

- The product must be installed only by a competent person with sufficient training in installation practices and with sufficient knowledge of good safety and installation practices in respect of electrical equipment. If local legislation contains provisions in respect of such training or sufficient knowledge in respect of installation of electrical equipment such provisions shall be fulfilled by the said person.
- Ensto accepts no liability concerning claims resulting from misuse, incorrect installation or ignored national safety regulations or other national provisions.
- **WARNING:** Failure to follow the installation instructions may result in damage to the product and serious or fatal injury.

## GENERAL INSTRUCTION FOR COLD SHRINK

- Ensure the cold shrink tubing is placed upon the cable core prior to installing the lug, for ease of assembly.
- When using cleaning solvents, ensure there is no residue remaining after cleaning. Solvent or other residue will impair the joint performance.
- Ensure that the plastic tape is straightened within the tube. If it is wrapped around the conductor, rotate the cold shrink assembly counter clockwise, to ensure the tape is straight, before attempting to withdraw the tape.
- Once you have correctly placed the cold shrink tube, the plastic spiral may be withdrawn with a steady pulling action. Take care to ensure the unwound spiral is not tightening around the cable. The excess spiral can be cut if required, as it is withdrawn.
- Double check the position of the tube as it begins to shrink. There is only a limited time to adjust the position of the tube

### SPIRAL POSITION BEFORE BEGINNING THE SHRINKING OF THE TUBE

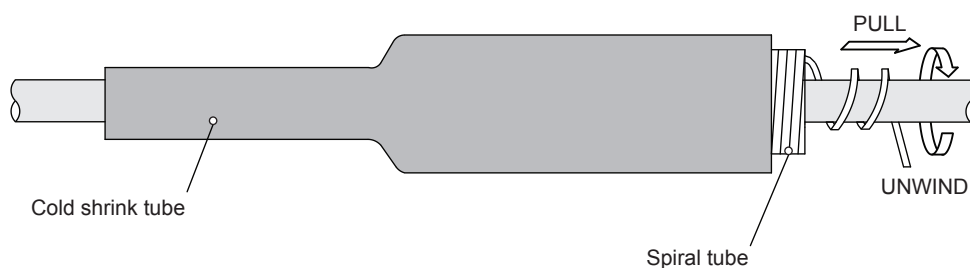
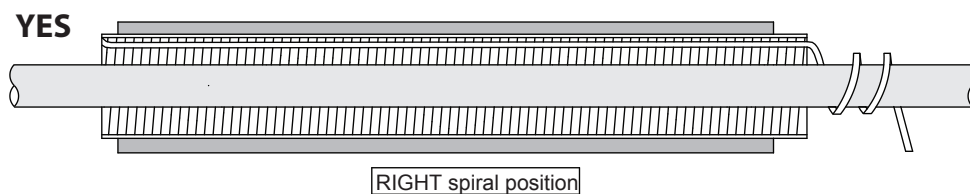
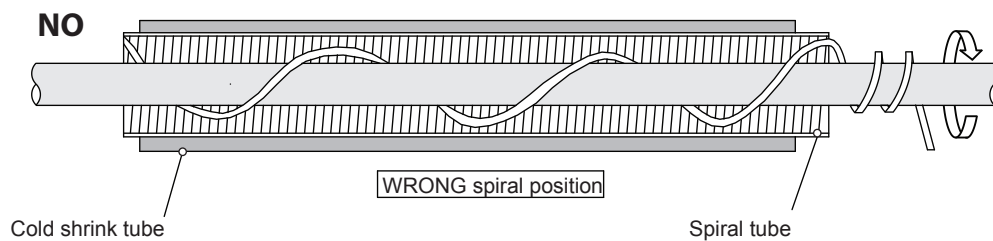

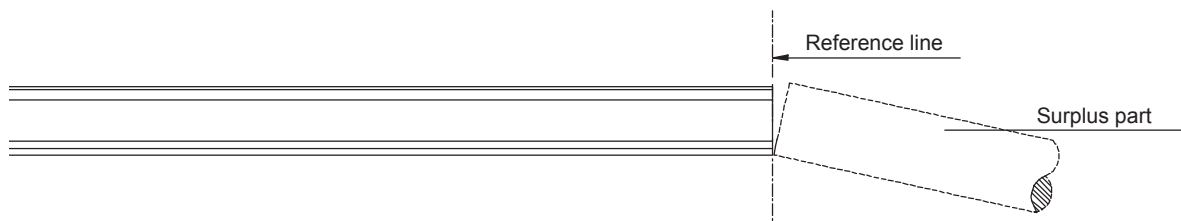

1.  Check the length of each core according to the final installed position.

**Table**

Type	Min. dia. on the cable insulation	36 kV mm <sup>2</sup>	42 kV mm <sup>2</sup>	Outer sheath removal A mm	Cable lug dimension C min dia.mm
COT1.4202	18,4	10-95	10-95	515	18,4
COT1.4203	25,3	70-300	50-300	555	25,3
COT1.4204	31,1	185-400	150-400	615	31,1
COT1.4205	31,1	400-630	400-630	615	31,1
COT1.4206	36,8	630-1000	630-1000	615	36,8
COT1.4202L	18,4	10-95	10-95	515	18,4
COT1.4203L	25,3	70-240	70-240	555	25,3
COT1.4204L	31,1	150-300	150-300	615	31,1
COT1.4205L	31,1	400-630	400-630	615	31,1
COT1.4206L	36,8	630-1000	630-1000	615	36,8

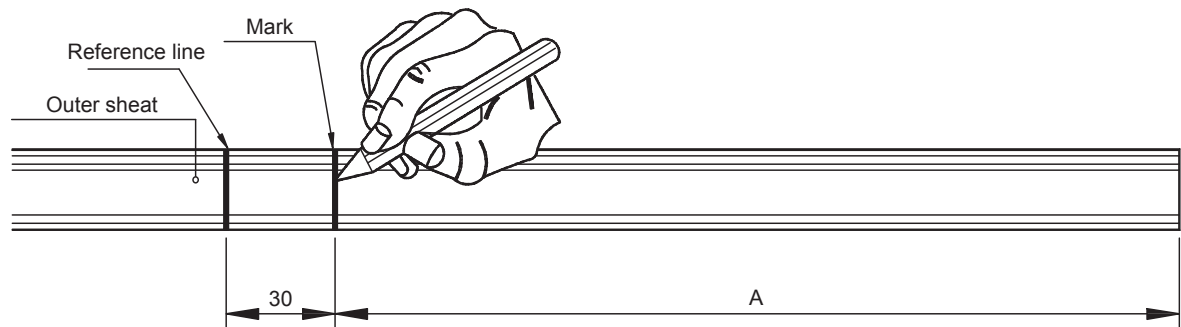

2.  Mark the cutting line at the distance of A mm from the core end and a reference line 30 mm from the cutting line.

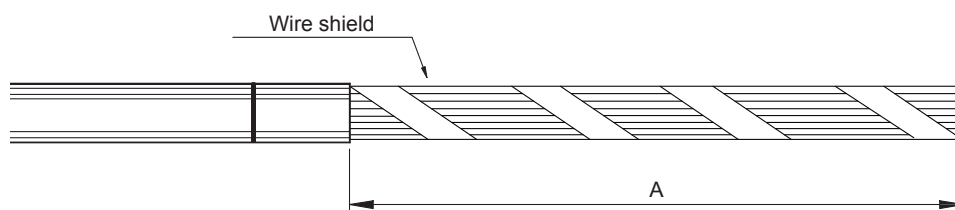

3.  Cut and remove the outer sheath and the possible tapes from the marked dimension.

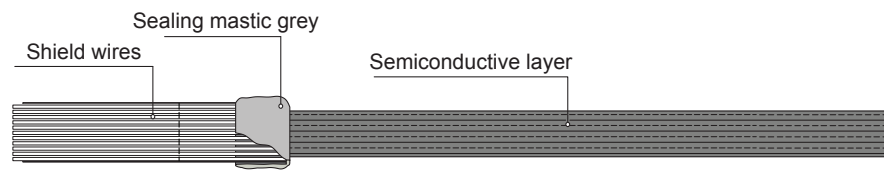

4.  Before folding the shield wires on the outer sheat, clean the outer sheat and shield wires for a distance of 20 mm measured from the outer sheat cut.
- Wrap one layer of grey sealing mastic around the outer sheat near the cut.
- Fold the shield wires on the outer sheat. If needed, fix the wires loosely with some PVC tape.
- Wrap another layer of grey sealing mastic on the shield wires directly over the previously applied layer of mastic.

*! Make sure the mastic is applied firmly and evenly.*

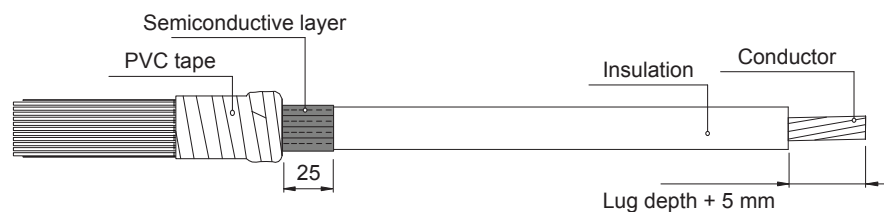

5.  Wrap tightly two layers of PVC tape starting from the grey mastic and move to the reference line.
- Remove the semiconductive layer leaving 25 mm measured from the outer sheat cut.
- If necessary, remove any remaining of the semiconductive layer with a piece of glass.
- Use the grinding paper to smooth the insulation.
- Remove the insulation for a length of the lug barrel depth + 5 mm. If compression lugs are used, remove the insulation following the lug manufacturer's instructions.
- Clean the conductor with a steel brush.

*! Make sure that the PVC tape is not applied on the semiconductive layer.*

*! Appropriate tools should be used to avoid any damage to the semiconductive layer or the conductor core.*

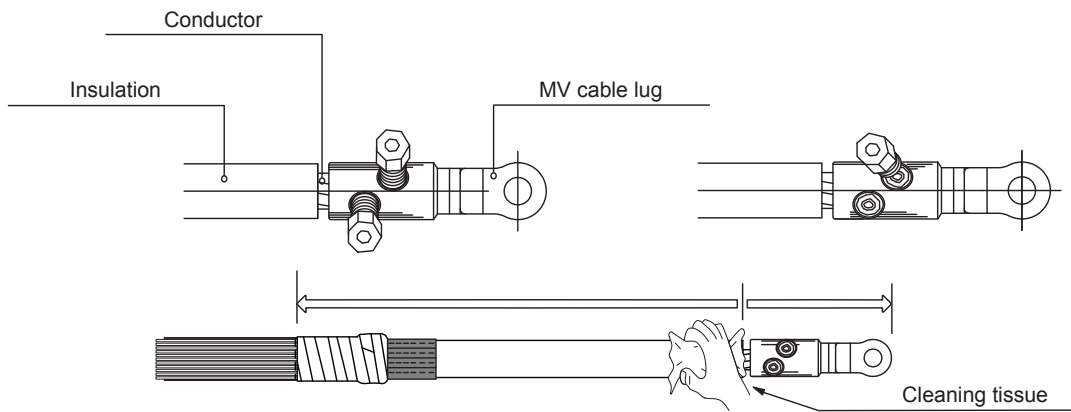

6.  Install a suitable cable lug according to the manufacturer's instructions.
- Clean the cable insulation and the semiconductive layer with a cleaning tissue starting from the insulation and move towards the semiconductive layer. Take care that no semiconductive particles are deposited on the insulation. Clean the cable lug starting from the barrel.

*! Orient the cable lug correctly.*

*! Remove all sharp edges from the cable lug.*

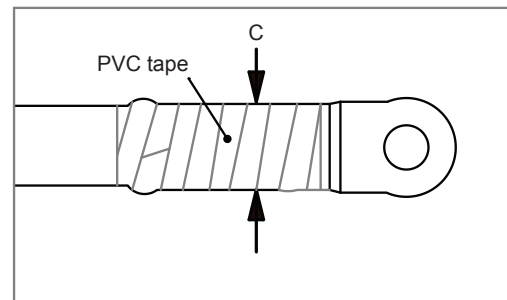
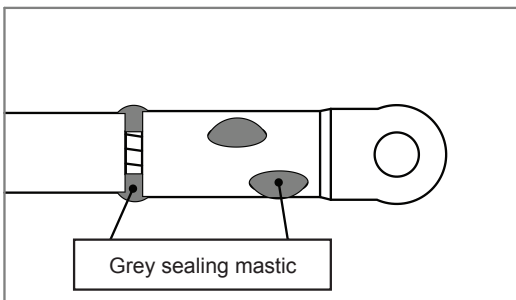

7.  Fill the gap between the cable lug and insulation with grey sealing mastic.
- Fill the voids on the lug with grey sealing mastic.
- Apply two layers of PVC tape to cover a few mm of the insulation and the barrel of the cable lug (check diameter C from the table).

*! Make sure the mastic is applied firmly and evenly.*

*! To increase diameter C (table 1), use the PVC tape.*

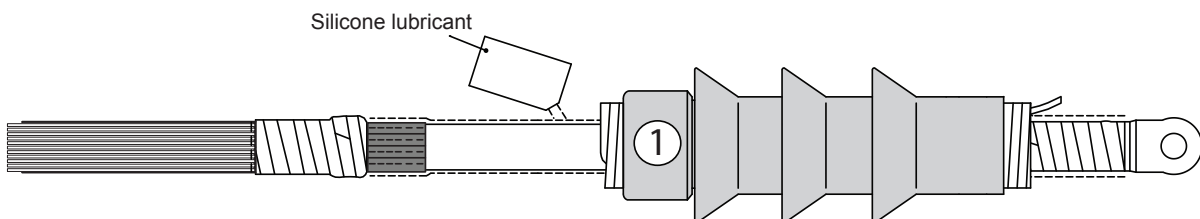

8.  Spread a thin, even layer of silicon lubricant over the taping, cable insulation and lug barrel. Leave some grease for step 13.
- Place the cold shrink stress control body over the prepared cable end.

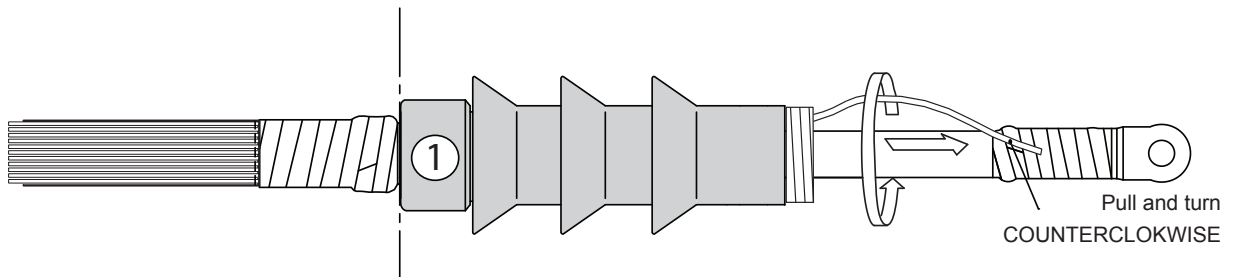

9.  Position the termination body to the end of the outer sheat cut and start pulling the spiral so that the termination body shrinks 1-2 cm from the end. If needed adjust the position of the termination body.
- Holding the termination body, pull out the spiral.
- ! If necessary, at this stage, minor repositioning of the body is still possible.*

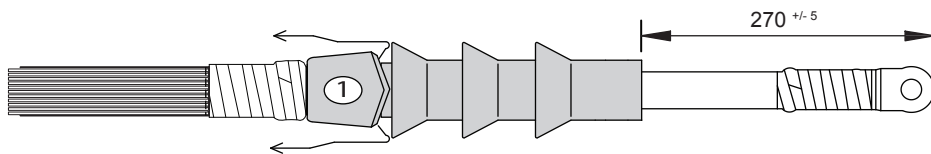

10.  Fold back the end of the termination body over the taped area, as shown in the picture.

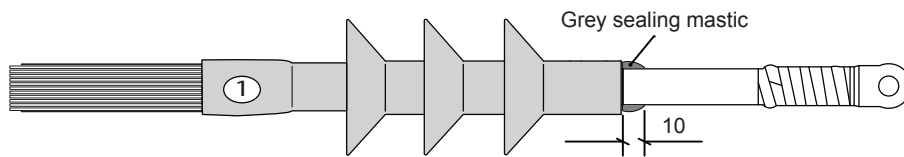

11.  Wrap one layer of sealing mastic and fill the step from the stress control body and the insulation of the cable. Fill about 10 mm as shown in the picture.
- ! Make sure the mastic is applied firmly and evenly.*

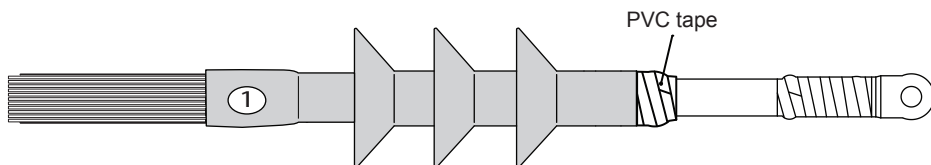

12.  Wrap firmly two layers of PVC tape on the sealing mastic.

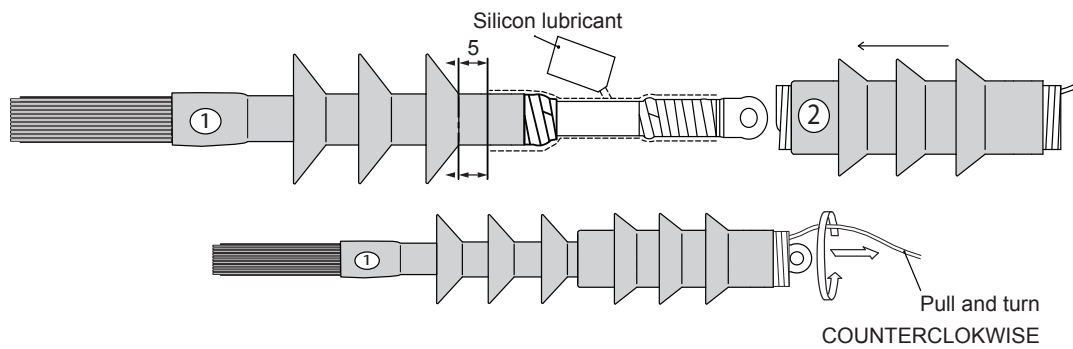

- 13.**  Make sure there is a thin and even layer of silicon lubricant on the insulation and the PVC taped area of the cable lug. Cover the previously taped area and a bit of the stress control body with a thin and even layer of silicon grease.
- Position the extension body approximately 5 mm from the rain shed of the stress control body. Start pulling the spiral so that the extension body shrinks 1-2 cm from the end. If needed adjust the position of the body
- Holding the extension body, pull out the spiral.

*! If necessary, at this stage, minor repositioning of the body is still possible.*

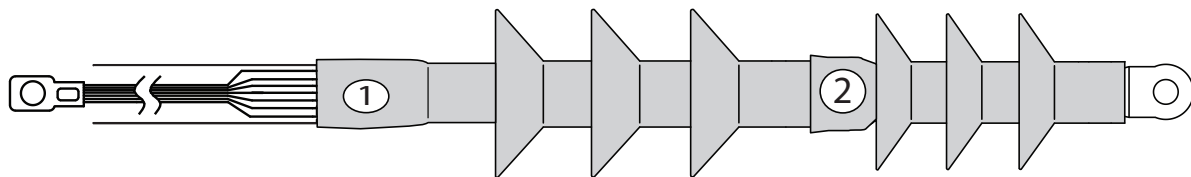

- 14.**  Braid the shield wire into a neat conductor and apply the earthing lug according to the manufacturer's instructions.
- 15.**  The termination is finished and ready to use!

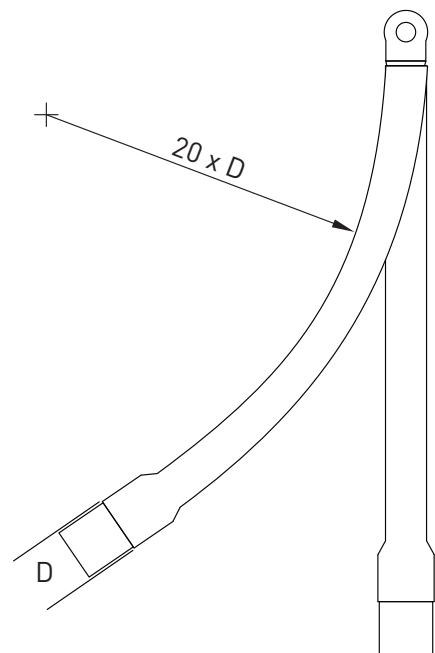
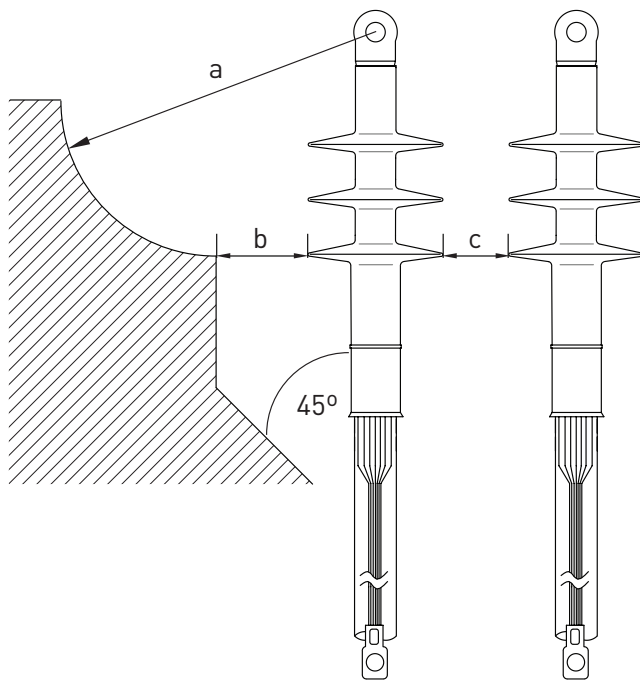
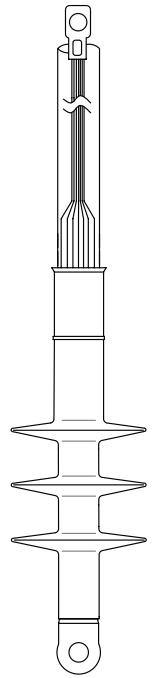
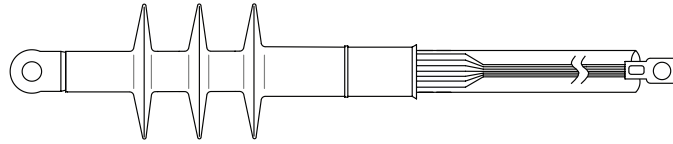
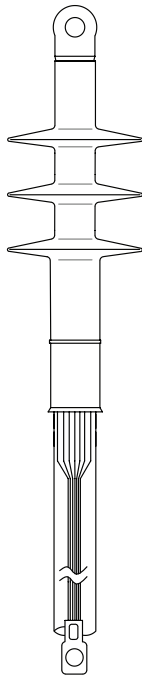

a = according to local requirements

Um kV	b min mm	c min mm
12	15	10
17.5	20	15
24	25	20
36	30	25
42	40	35



*Saves Your Energy*

ENSTO FINLAND OY  
ENSIO MIETTISEN KATU 2, P.O.BOX 77  
06101 PORVOO, FINLAND  
TEL. +358 204 76 21  
FAX +358 204 762 770  
UTILITY.NETWORKS@ENSTO.COM

[WWW.ENSTO.COM](http://WWW.ENSTO.COM)