



Saves Your Energy

INSTALLATION INSTRUCTION

PEM1421

2014-03

**SMJ1.27, SMJ2.47 & SMJ3.47**  
**SML1.17, SML1.172, SML2.27 & SML2.272**

<p>Read working instructions before installation. Before installation, check the materials for completeness. Install very carefully, be sure that the materials are clean during the installation and clean the working place after installation. Manufacturer accepts no liability for breakdowns resulting from incorrect installation.</p>	ENG
<p>Před montáží pozorně prostudujte instrukce. Pečlivě zkontrolujte úplnost balení. Montáž provádějte velmi opatrně, ujistěte se zda jsou všechny komponenty během montáže čisté, rovněž uklidte pracovní místo po skončení montáže. Výrobce nezodpovídá za žádné škody a poruchy způsobené chybnou nebo nedbalou montáží.</p>	CZE
<p>Enne tööle asumist loe läbi paigaldusjuhend. Enne tööle asumist veendu kõigi tarvikute olemasolus. Paigalda ettevaatlikult; jälgi, et tarvikud oleks puhtad kogu paigalduse kestel; puhasta töökoht pärast paigalduse lõppu. Tootja ei vastuta toote vales paigaldusest põhjustatud kahjude eest.</p>	EST
<p>Lue asennusohjeet tarkasti ennen asennusta. Ennen asennusta, tarkista että pakkauksessa on kaikki tarvittavat tarvikkeet. Suorita asennus erittäin huolellisesti, varmista että asennustarvikkeet ovat puhtaat ja siivoa asennuspaikka asennuksen jälkeen. Valmistaja ei vastaa väärästä asennustavasta johtuvista vioista.</p>	FIN
<p>Lire attentivement les instructions de montage avant l'installation. Avant l'installation, vérifiez que le produit convient à l'application, ainsi que la présence de toutes les pièces. Installer très attentivement, s'assurer que le matériel reste propre lors de l'installation et nettoyer le lieu de travail après l'installation. Le fabricant décline toute responsabilité quant à des dégradations résultant d'une installation incorrecte.</p>	FRA
<p>Olvassa el a szerelési utasítást a szerelés megkezdése előtt. Szerelés előtt ellenőrizze, hogy az anyagok hiánytalanul meg vannak-e. Végezze a szerelést nagyon körültekintően, tartsa tisztán az anyagokat, a szerelvényt és a környezetet. A gyártó nem vállalhatja a felelősséget, ha helytelen szerelés miatt a szerelvény meghibásodik.</p>	HUN
<p>Pirms montāžas rūpīgi izlasiet montāžas instrukciju. Pirms montāžas pārbaudiet vai montāžas komplekts satur visas detaļas. Montāžu ir jāveic rūpīgi, nodrošinot, lai visi materiāli būtu tīri. Ražotājs neuzņemas atbildību par izstrādājumu, to nepareizas montāžas gadījumā.</p>	LVA
<p>Prieš montavimą perskaitykite montavimo instrukciją. Prieš montavimą įsitikinkite, kad komplektas yra pilnas. Montuokite labai atidžiai, įsitikinkite, kad visos medžiagos yra švarios ir po montavimo sutvarkykite darbo vietą. Gamintojas neatsako už neteisingo montavimo pasekmes.</p>	LTU
<p>Les hele montasjebeskrivelsen før man begynner montasjen. Kontroller innholdet før man begynner montasjen. Vær nøye med montasjen. Sørg for at alt materiell som inngår i montasjen holdes rent. Alt avfall skal håndteres iht gjeldende miljøbestemmelser. Produsenten påtar seg ikke ansvaret for feil som oppstått på grunn av feil montasje.</p>	NOR
<p>Przed montażem przeczytać instrukcję. Sprawdzić kompletność zestawu. Montować starannie. Podczas montażu upewnić się, że materiały są czyste. Po instalacji oczyścić miejsce montażu. W przypadku niewłaściwego montażu producent nie ponosi odpowiedzialności za awarie.</p>	POL
<p>Ознакомьтесь с инструкцией до проведения работ. Перед установкой убедитесь в правильном выборе материалов. При проведении работ будьте внимательны, соблюдайте чистоту деталей до и вовремя проведения работ. Производитель не несет ответственности за повреждения, вызванные некорректным монтажом.</p>	RUS
<p>Läs igenom monteringsanvisningen noggrant, innan montering påbörjas. Kontrollera att allt material finns med. Var noggrant med montaget, säkerställ att materialet är rent under monteringen och städa upp arbetsplatsen efter färdiggjord installation. Producenten accepterar inga ersättningskrav för fel, som kan hänföras till felaktig installation.</p>	SWE











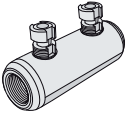

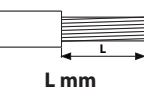

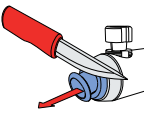
Saves Your Energy

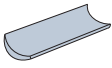
INSTALLATION INSTRUCTION

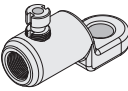
PEM1421

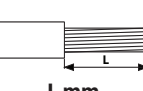
2014-03

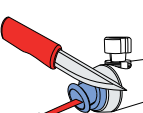
							
SMJ1.27 10-95 mm <sup>2</sup>	10-50	25-35	35	X			-
	70-95	50-70	33			X	-
SMJ2.47 70-240 mm <sup>2</sup>	50	-	65	X			SMJT2
	70-95	-	65	X			-
	120-150	70-95	63	X	X		-
	185-240	120-150	59			X	-
SMJ3.47 120-300 mm <sup>2</sup>	70-95	-	72	X			SMJT3
	120	-	72	X			-
	150-185	120	69	X	X		-
	240-300	150-240	65			X	-

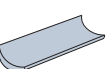
							
SML1.17 SML1.172 10-95 mm <sup>2</sup>	10-50	25-35	35	X			-
	70-95	50-70	33			X	-
SML2.27 SML2.272 70-240 mm <sup>2</sup>	50	-	65	X			SMJT2
	70-95	-	65	X			-
	120-150	70-95	61	X	X		-
	185-240	120-150	58			X	-
SML3.27 SML3.272 120-300 mm <sup>2</sup>	70-95	-	72	X			SMJT3
	120	-	72	X			-
	150-185	120	69	X	X		-
	240-300	150-240	65			X	-

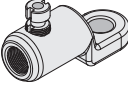
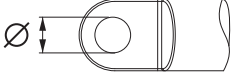
	
SML1.17	13 mm
SML1.172	17 mm
SML2.27	13 mm
SML2.272	17 mm
SML3.27	13 mm
SML3.272	17 mm

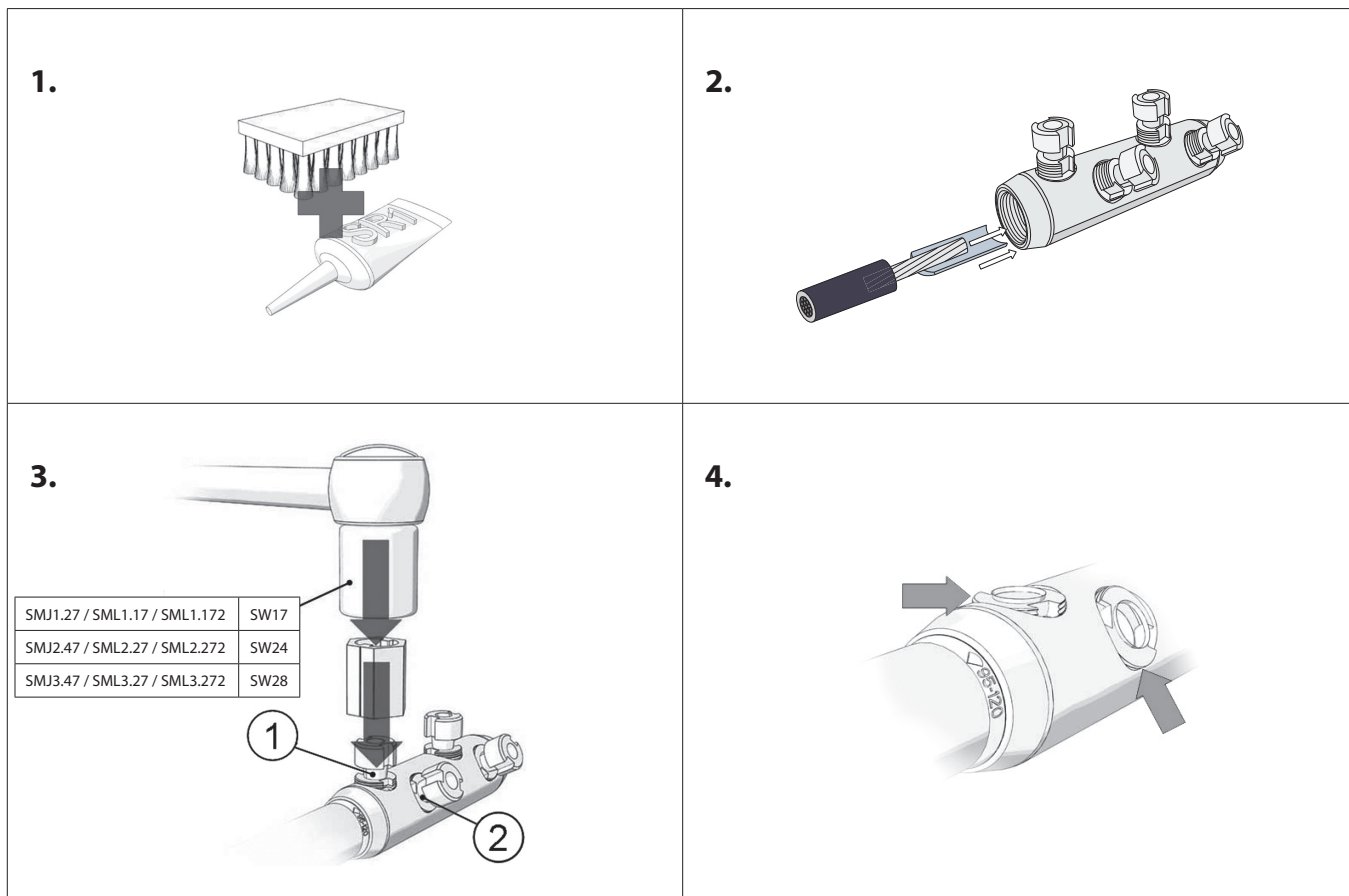

**1. (ENG)** For aluminium conductors. **(CZE)** Pro Al vodiče a kabely. **(EST)** Alumiiniumjuhtidele. **(FIN)** Alumiinijohtimille. **(FRA)** Pour conducteurs en aluminium. **(HUN)** Aluminium vezetőkhöz. **(LVA)** Alumīnija dzīslām. **(LTU)** Aliuminio laidininkams. **(NOR)** For aluminiums leder. **(POL)** W przypadku żył aluminiowych. **(RUS)** Для алюминиевых проводников. **(SWE)** För aluminium ledare.

**4. (ENG)** Round sharp edges. **(CZE)** Zakulatte ostré hrany. **(EST)** Tasanda teravad väljaulatuvad osad. **(FIN)** Pyöristä terävät tai ulkonevat osat (kulmat). **(FRA)** Arrondir les arêtes vives. **(HUN)** Távolítsa el a keletkezett éleket. **(LVA)** Noapaļojiet asās malas. **(LTU)** Užapvalinkite aštrius kampus. **(NOR)** Avrund skarpe kanter. **(POL)** Stępić ostre krawędzie. **(RUS)** Скруглите все острые грани. **(SWE)** Knacka ner skarpa kanter.





*Saves Your Energy*

**INSTALLATION INSTRUCTION**

**PEM1421**

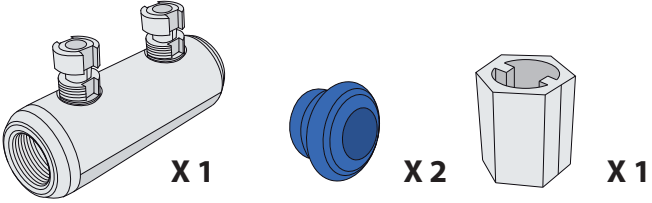
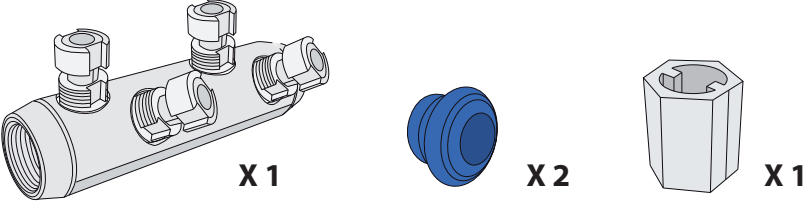
**2014-03**

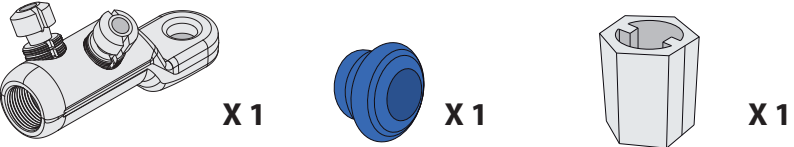
<p><b>SMJ1.27</b></p>	 <p>X 1      X 2      X 1</p>
<p><b>SMJ2.47</b> <b>SMJ3.47</b></p>	 <p>X 1      X 2      X 1</p>
<p><b>SML1.17</b> <b>SML1.172</b></p>	 <p>X 1      X 1      X 1</p>
<p><b>SML2.27</b> <b>SML2.272</b> <b>SML3.27</b> <b>SML3.272</b></p>	 <p>X 1      X 1      X 1</p>